

Fig. 351S Flame Arrestor

Specification Sheet

The Fig. 351S Flame Arrestor can be purchased with our Fig. 354 Open Updraft Vent or with our Fig. 748A Pressure Vacuum Vent.

In either configuration, the Flame Arrestor helps prevent the transmission of heat and/or an ignition source into the tank.

Construction Details for Flame Arrestor:

Body: Cast Iron
 Cover: Cast Iron
 Cap: Brass
 Arrestor Plates: Stainless Steel

Standard Features:

Gauge Opening Cap

For more information on the 354 or the 748A please refer to our website at www.morbros.com or contact our Customer Service Department.

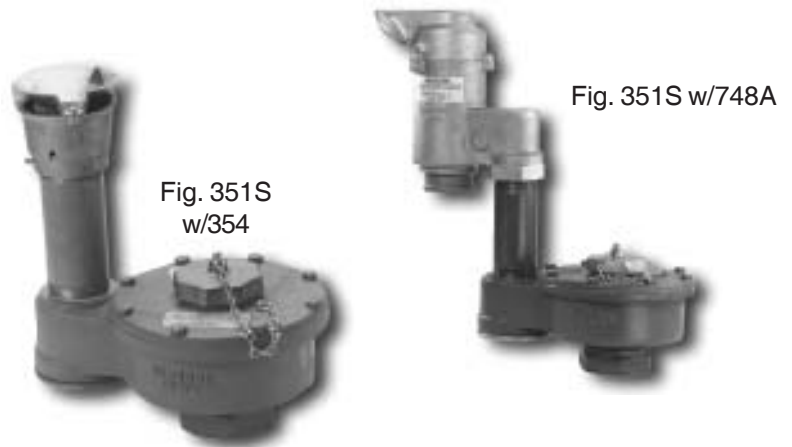

Fig. 351S w/354

Fig. 351S w/748A

	Pressure Setting (oz/sq in)	Vacuum Setting (oz/sq in)	Ship Weight (lbs)	Venting Capacity (CFH) (@2.5 PSI)
W/354	N/A	N/A	31.00	22,000
W/748A	2.0	1.0	42.00	15,500
W/748A	4.0	1.0	42.50	15,500
W/748A	6.0	1.0	42.75	15,500
W/748A	8.0	1.0	43.50	15,500
W/748A	12.0	1.0	44.50	13,000
W/748A	16.0	1.0	45.75	13,000

WARNING: DO NOT FILL OR UNLOAD FUEL FROM A STORAGE TANK UNLESS IT IS CERTAIN THAT THE TANK VENTS WILL OPERATE PROPERLY. Morrison tank vents are designed only for use on shop fabricated atmospheric tanks which have been built and tested in accordance with UL 142, NFPA 30 & 30A, and API 650 and in accordance with all applicable local, state, and federal laws. In normal operation, dust and debris can accumulate in vent openings and block air passages. Certain atmospheric conditions such as a sudden drop in temperature, below freezing temperatures, and freezing rain can cause moisture to enter the vent and freeze which can restrict internal movement of vent mechanisms and block air passages. All storage tank vent air passages must be completely free of restriction and all vent mechanisms must have free movement in order to insure proper operation. Any restriction of airflow can cause excessive pressure or vacuum to build up in the storage tank, which can result in structural damage to the tank, fuel spillage, property damage, fire, injury, and death. Monthly inspection, and immediate inspection during freezing conditions, by someone familiar with the proper operation of storage tank vents, is required to insure venting devices are functioning properly before filling or unloading a tank.

WARNING: Do not use with acetylene, carbon disulfide, etheleneoxide or hydrogen gases. For use with normal hydrocarbon flames such as gasoline in air.

WARNING: Routine inspection is required to ensure airways are clear and free of debris. Blocked airways can cause structural deformation of the tank.

WARNING: Normal vents such as pressure vacuum and updraft vents for aboveground storage tanks should be sized according to NFPA 30 (2003) 4.2.5.1.2.