

Model 245 Emergency Vents

SPECIFICATION SHEET

Application

This lightweight, spring-loaded emergency vent (pressure relief only) is used on aboveground storage tanks, as a code requirement, to help prevent the tank from becoming over-pressurized and possibly rupturing if ever exposed to fire. This vent must be used in conjunction with a "normal vent." Correct application of this vent requires proper vent size and selection for the tank system in order to meet the specific venting capacity.

Materials of Construction

- Body... Aluminum
- Cover... Aluminum
- Seat... FKM
- Bolt... Zinc plated steel

Code Compliance

NFPA 1, 30, 30A, 31, 37, 110; PEI RP200, PEI RP800; UL 142, UL 142A, UL 2085, UL 2244; CAN/ULC S601, CAN/ULC S602, CAN/ULC S652

Approvals

Underwriters Laboratories Inc. UL-2583



4" vent (245M)



4" vent (245F)



6" vent (245)

NOTE

Emergency vent should be set higher than the normal vent so the normal vent operates first.

WARNING: DO NOT FILL OR UNLOAD FUEL FROM A STORAGE TANK UNLESS IT IS CERTAIN THAT THE TANK VENTS WILL OPERATE PROPERLY.

Morrison tank vents are designed only for use on shop fabricated atmospheric tanks which have been built and tested in accordance with UL 142, NFPA 30 & 30A, and API 650 and in accordance with all applicable local, state and federal laws. In normal operation, dust and debris can accumulate in vent openings and block air passages. Certain atmospheric conditions such as a sudden drop in temperature, below freezing temperatures, and freezing rain can cause moisture to enter the vent and freeze which can restrict internal movement of vent mechanisms and block air passages. All storage tank vent air passages must be completely free of restriction and all vent mechanisms must have free movement in order to insure proper operation. Any restriction of airflow can cause excessive pressure or vacuum to build up in the storage tank, which can result in structural damage to the tank, fuel spillage, property damage, fire, injury, and death. Monthly inspection, and immediate inspection during freezing conditions, by someone familiar with the proper operation of storage tank vents, is required to insure venting devices are functioning properly before filling or unloading a tank. Normal vents such as pressure vacuum and updraft vents for aboveground storage tanks should be sized according to NFPA 30 (2008) 21.4.3

245 part numbers and diagrams on next page...

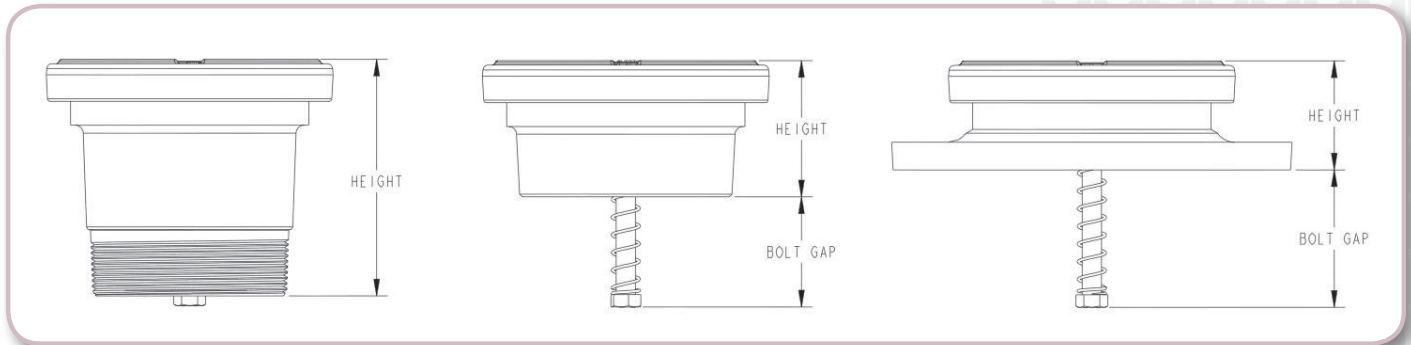

Item Number	A	B	C	D	Overall Diameter	Height	Bolt Gap	Weight	Screen
245M--0200 AV	2"	31,917	M	8	3.00	1.50	1.60	0.50	
245MS-0200 AV	2"	24,069	M	8	3.00	1.50	1.60	0.50	S
245--0300 AV	3"	67,162		8	5.00	2.80	0.90	2.80	
245S--0300 AV	3"	56,241		8	5.00	2.80	0.90	2.80	S
245M--0300 AV	3"	67,162	M	8	5.00	3.60	< 1/4"	2.50	
245MS-0300 AV	3"	56,241	M	8	5.00	3.60	< 1/4"	2.50	S
245--0400 AV	4"	129,369		8	6.50	3.10	2.50	3.30	
245S--0400 AV	4"	115,086		8	6.50	3.10	2.50	3.30	S
245M--0400 AV	4"	129,369	M	8	6.00	5.40	< 1/4"	4.50	
245MS-0400 AV	4"	115,086	M	8	6.50	5.40	< 1/4"	4.50	S
245F--0400 AV †	4"	129,369	F	8	9.10	2.50	3.00	6.00	
245FS-0400 AV	4"	115,086	F	8	9.10	2.50	3.00	6.00	S
245--0600 AV	6"	331,750		8	8.50	3.40	2.60	5.50	
245S--0600 AV	6"	277,011		8	8.50	3.40	2.60	5.50	S
245M--0600 AV	6"	331,750	M	8	8.50	5.40	0.80	6.20	
245MS-0600 AV	6"	277,011	M	8	8.50	5.40	0.80	6.20	S
245F--0600 AV †	6"	331,750	F	8	11.00	2.90	3.20	9.10	
245FS-0600 AV	6"	277,011	F	8	11.00	2.90	3.20	9.10	S
245--0800 AV	8"	527,441		8	10.50	4.50	1.50	9.20	
245M--0800 AV	8"	527,441	M	8	10.50	5.70	0.40	10.10	
245F--0800 AV †	8"	527,441	F	8	13.50	3.30	2.90	14.50	
245F--1000 AV †	10"	972,110	F	8	16.00	2.80	6.00	20.00	

*Refer to Price List for BSP options.

† Indicates model is available in a kit.

SPECIFICATION OPTIONS:

- A**—Size (inches)
- B**—Venting capacity/SCFH
- C**—Mounting connection: Male N.P.T. (M), Female N.P.T. (BLANK), Flanged (F)
- D**—Pressure settings: 8oz/in² (pressure required to open vent)
- Diameter**—Dimension across vent (inches)
- Height**—Dimension from base to top when closed (inches)
- Bolt Gap**—Dimension from base to bottom of bolt
- Weight**—Shipping weight (lbs)
- Screen (3 mesh stainless steel)**—Yes (S), No (blank)

Size	Item Number	Flanged Kits	Bolt Size
4"	245F--0408 AK	Includes 245F--0400 AV vent, flange adaptor, gasket, and (8) nuts/bolts	0.625" dia; 2" length
6"	245F--0608 AK	Includes 245F--0600 AV vent, flange adaptor, gasket, and (8) nuts/bolts	0.75" dia; 2.75" length
8"	245F--0808 AK	Includes 245F--0800 AV vent, flange adaptor, gasket, and (8) nuts/bolts	0.75" dia; 2.75" length
10"	245F--1008 AK	Includes 245F--1000 AV vent, flange adaptor, gasket, and (12) nuts/bolts	0.875" dia; 3" length

