

INSTALLATION INSTRUCTIONS



Overfill Warning Valve

FMMATO-91

The FMMATO-91 Overfill Warning Valve (OWV) is used in sump-type applications. The OWV opens as the tank approaches full capacity, allowing air to flow to drive the pump.

SPECIFICATIONS

Air Inlet	1/4" Female N.P.T.
Air Outlet	1/4" Female N.P.T.
Signal Port	1/8" Female N.P.T.
Mounting	2" Male N.P.T.
Maximum Air Pressure	150 PSI
Air Flow Capacity	20 CFM @ 100 PSI
Operating Temperature	-10° to 185° F
Weight	2 lbs

GENERAL SAFETY REQUIREMENTS

The following safety precautions need to be observed before operating the unit:

1. DO NOT exceed the pressure rating of any component in the system.
2. Read all instruction sheets, and any other explanatory material before attempting to operate, assemble, or disassemble the system.
3. Protect all material and air supply lines from puncture or damage. Especially be aware of places where lines or hoses may be damaged when flexing or twisting, or by hot machinery or moving parts.
4. All lines should be inspected daily for weak or worn condition prior to work operations.
5. Disconnect air and material supply lines and relieve pressure prior to removing or servicing any component in the system.

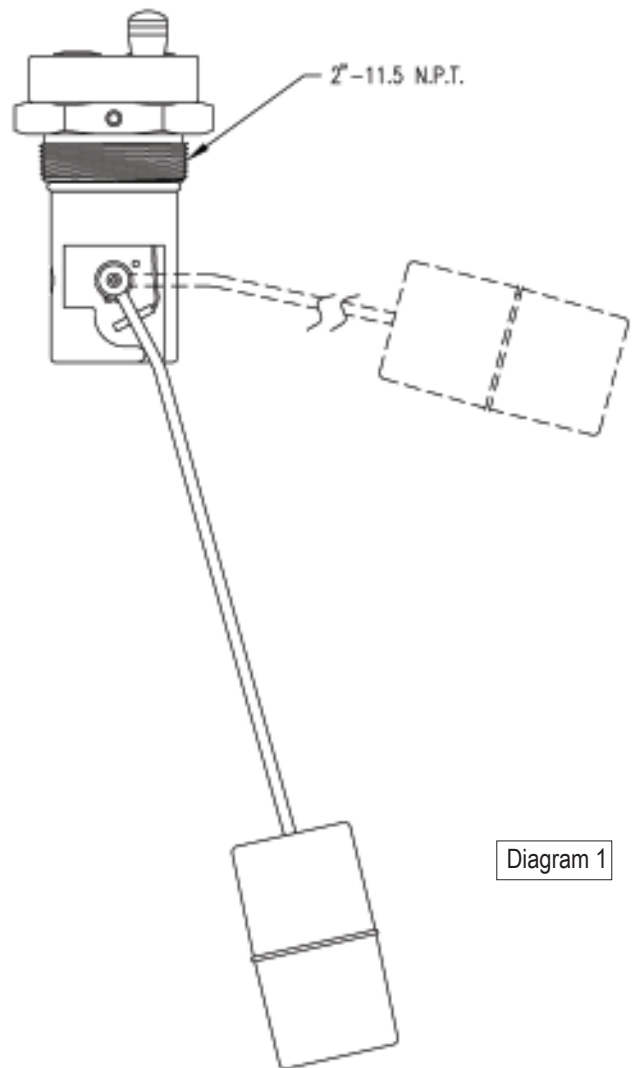

Diagram 1

**FMMATO-91
Overfill Warning Valve**

For further service, contact your local Morrison distribution center.



Morrison Bros. Co.

325 East 24th Street • Dubuque, IA 52001

Tel: 800-553-4840 Fax: 563-583-5028

E-Mail: custserv@morbros.com



CAUTION

The Overfill Warning Valve is not intended to reduce or replace user responsibility when transferring liquids to a tank.

INSTALLATION

NOTE: Reduce air pressure in airline to zero prior to connecting the Overfill Warning Valve.

1. Check tank for obstructions that could block the movement of the float.

NOTE: Install the OWV in a manner that will allow the float to move freely.

2. Back off set screw in threaded collar enough that the collar will rotate freely around OWV body (Diagram 1).
3. Insert OWV assembly into bung opening at the top of the tank. The float indicator "ARROW" on the top of OWV must point to the area selected for float operation (Diagram 2).

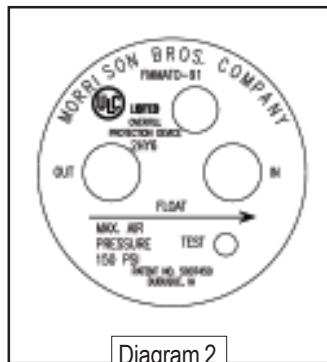
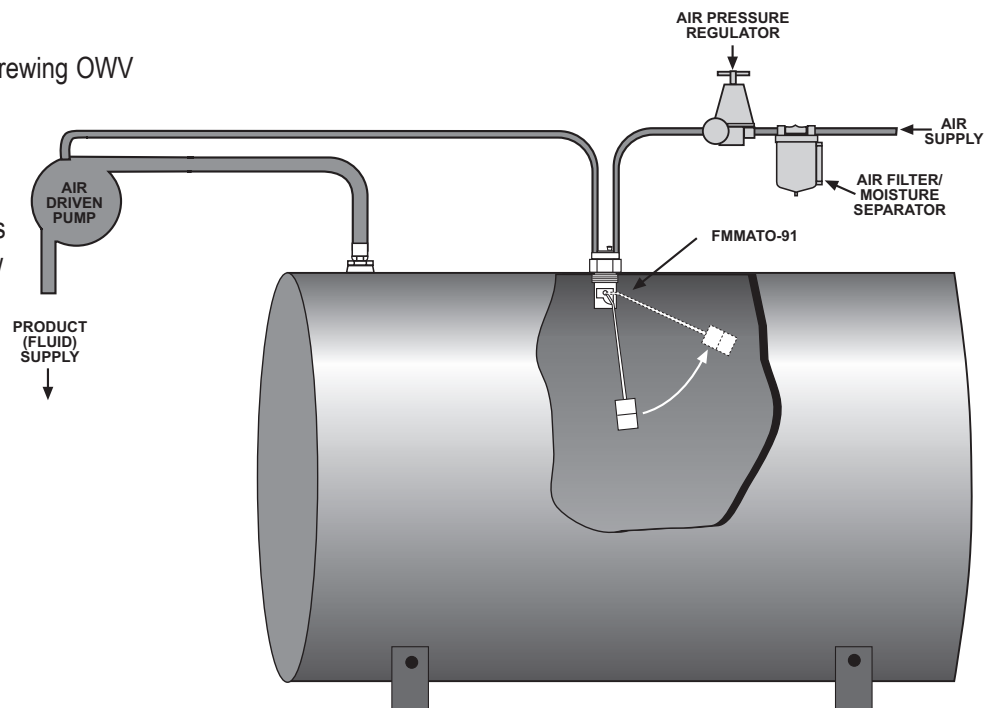

Diagram 2

4. Hold top of the OWV in position while screwing OWV collar into tank.
5. Ensure that the float indicator "ARROW" is in desired operating position before tightening collar set screw. The OWV is in operating position when the set screw is tightened.
6. Connect air supply to the "IN" port and connect the pump's air inlet to the "OUT" port on the OWV.



NOTE: The air filter/moisture separator, regulator, oiler (if used - see Pump Instructions) and any air valves should be placed in the air line before the Overfill Warning Valve. (The air line to the "IN" port of the valve).

NOTE: If an oiler is used, hydraulic oil or 10 weight motor oil should be used in it. Antifreeze can be used whenever the combination of extreme cold weather and wet air are present.

MAINTENANCE

NOTE: The Overfill Warning Valve is similar to a fine air tool and its life and performance can be drastically reduced by air that has not been filtered to remove moisture and particle contamination.

1. The Overfill Warning Valve should be tested several times a year. The test is performed by lifting the test button about one inch. This should open valve, allowing air to the pump. When the button is released, the OWV should reset.

CAUTION: All worn or damaged parts are a threat to personnel and property and need to be replaced.